

Load Rating Chart

Model 40124SHL



© Manitex 2000

NOTE: Additional copies of this Load Rating Chart can be purchased from your Manitex Distributor. When ordering, use the part number shown in the bottom left corner of this page.

RANGE DIAGRAM - FULLY EXTENDED OUTRIGGER CONFIGURATION -

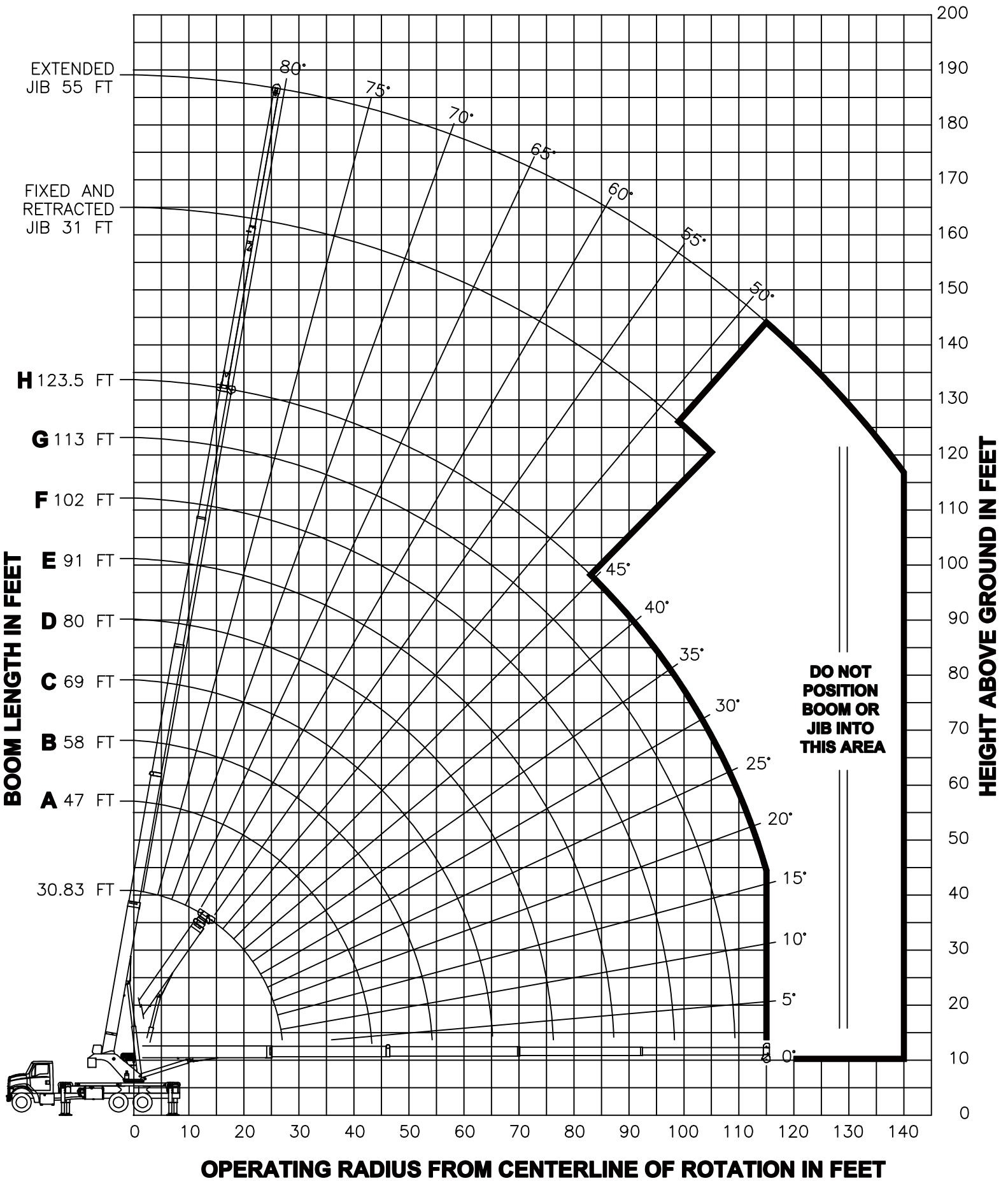

**USE THIS CHART ONLY
WHEN ALL
OUTRIGGERS ARE
FULLY EXTENDED**

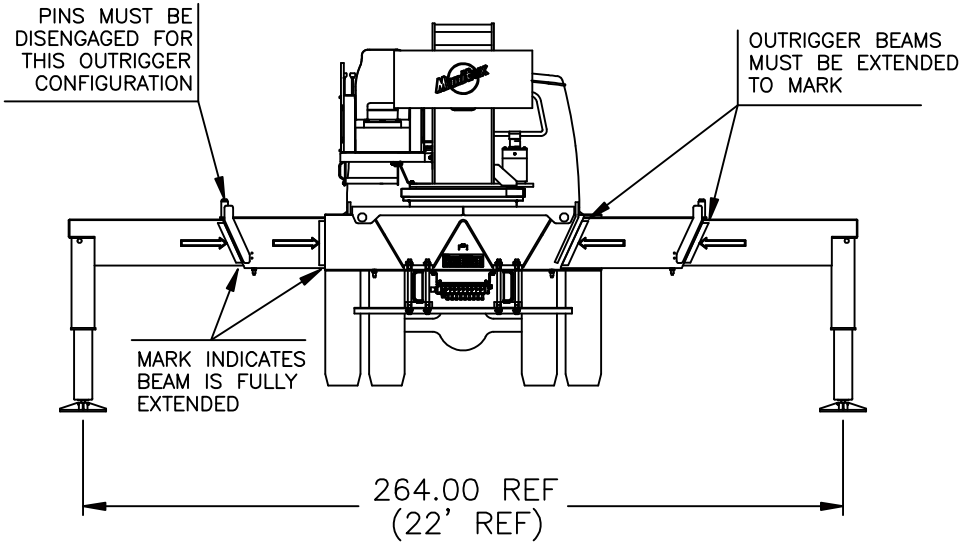

- FULLY EXTENDED OUTRIGGER CONFIGURATION -

MAIN BOOM LMI CODE 1																			
LOAD RADIUS (FT)	30.833 FT		47 FT (A)		58 FT (B)		69 FT (C)		80 FT (D)		91 FT (E)		102 FT (F)		113 FT (G)		123.5 FT (H)		LOAD RADIUS (FT)
	∠	LOAD CAPACITY (LBS)	∠	LOAD CAPACITY (LBS)	∠	LOAD CAPACITY (LBS)	∠	LOAD CAPACITY (LBS)	∠	LOAD CAPACITY (LBS)	∠	LOAD CAPACITY (LBS)	∠	LOAD CAPACITY (LBS)	∠	LOAD CAPACITY (LBS)	∠	LOAD CAPACITY (LBS)	
5	75	80000																	5
8	69	60500																	8
10	64	52550	74	25000															10
12	60	46600	72	25000	76	25000	79	25000											12
15	53	39600	68	25000	73	25000	76	25000	79	21500									15
20	40	31330	61	25000	67	25000	72	23900	75	19700	78	17100	79	14500					20
25	22	24100	53	24010	62	22840	67	21650	71	18200	74	15850	77	13500	78	10910	80	8450	25
30			45	20260	56	19550	63	18720	67	16250	71	14530	74	12820	76	10430	78	8150	30
35			36	15850	49	16100	58	16130	63	14540	68	12960	71	11380	73	9540	75	7800	35
40			22	12630	42	12900	52	13060	59	13070	64	11610	68	10160	71	8680	72	7280	40
45					34	10540	47	10700	55	10800	60	10600	65	9370	68	8040	70	6780	45
50					23	8720	40	8890	50	9000	56	9070	61	8430	65	7260	67	6160	50
55							34	7460	45	7570	52	7640	58	7620	62	6550	65	5540	55
60							24	6280	39	6400	48	6480	54	6530	59	5930	62	5000	60
65							6	5270	33	5430	43	5510	51	5570	56	5380	59	4520	65
70									25	4610	38	4700	47	4760	53	4790	57	4090	70
75									12	3900	32	4010	42	4060	49	4100	54	3700	75
80											25	3400	37	3470	45	3510	51	3350	80
85											15	2860	32	2940	41	2990	47	3020	85
90													26	2480	37	2530	44	2560	90
95													17	2060	32	2120	40	2150	95
100															26	1750	36	1790	100
105															18	1410	31	1460	105
110																	26	1160	110
115																	19	880	115
120																			120
	450 LBS	300 LBS	240 LBS	200 LBS	180 LBS	160 LBS	140 LBS	130 LBS	120 LBS	120 LBS	120 LBS	120 LBS	120 LBS	120 LBS	120 LBS	120 LBS	120 LBS	120 LBS	STOWED FIXED JIB
	840 LBS	560 LBS	450 LBS	380 LBS	330 LBS	290 LBS	260 LBS	230 LBS	210 LBS	210 LBS	210 LBS	210 LBS	210 LBS	210 LBS	210 LBS	210 LBS	210 LBS	210 LBS	STOWED TELE JIB

**DEDUCTIONS FROM MAIN BOOM
CAPACITIES FOR STOWED JIBS**

**USE THIS CHART ONLY
WHEN ALL
OUTRIGGERS ARE
FULLY EXTENDED**

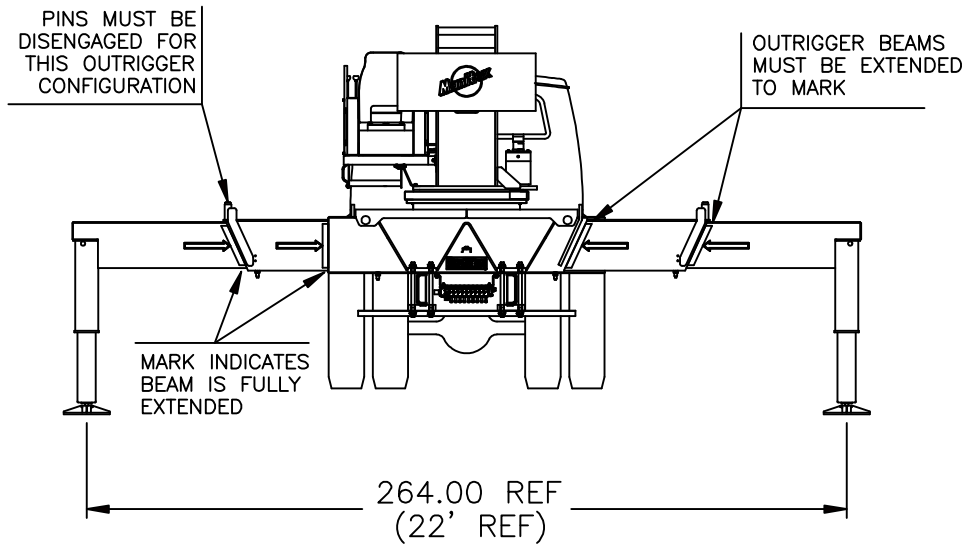

- FULLY EXTENDED OUTRIGGER CONFIGURATION -

JIB LOAD CAPACITIES

LOAD RADIUS (FT) REF	31 FT FIXED JIB LMI CODE 32		30.5 FT TELE JIB LMI CODE 7		55 FT TELE JIB LMI CODE 13		LOAD RADIUS (FT) REF
	LOADED BOOM ANGLE (DEG)	LOAD CAPACITY (LBS)	LOADED BOOM ANGLE (DEG)	LOAD CAPACITY (LBS)	LOADED BOOM ANGLE (DEG)	LOAD CAPACITY (LBS)	
30	80	4000	79.5	3300			30
35	78	3850	77.5	3300	79.5	2450	35
40	76	3700	76	3300	78	2450	40
45	74	3550	74	3300	76.5	2450	45
50	72	3400	72	3300	75	2450	50
55	70	3250	70.5	3300	73	2450	55
60	68	3080	68.5	3300	71.5	2450	60
65	66	2910	66.5	3070	70	2420	65
70	64	2750	64.5	2750	68	2260	70
75	62	2600	62	2380	66	2110	75
80	60	2460	60	2050	64.5	1940	80
85	58	2320	58	1760	63	1750	85
90	55	2170	55.5	1500	61	1580	90
95	53	1930	53	1260	59	1440	95
100	51	1720	50.5	1050	57	1280	100
105	48	1530	48	850	55	1100	105
110	45	1350			53	930	110
115	43	1200			51	770	115
120	40	1020					120
125	36	800					125
130							130

RANGE DIAGRAM - INTERMEDIATE OUTRIGGER CONFIGURATION -

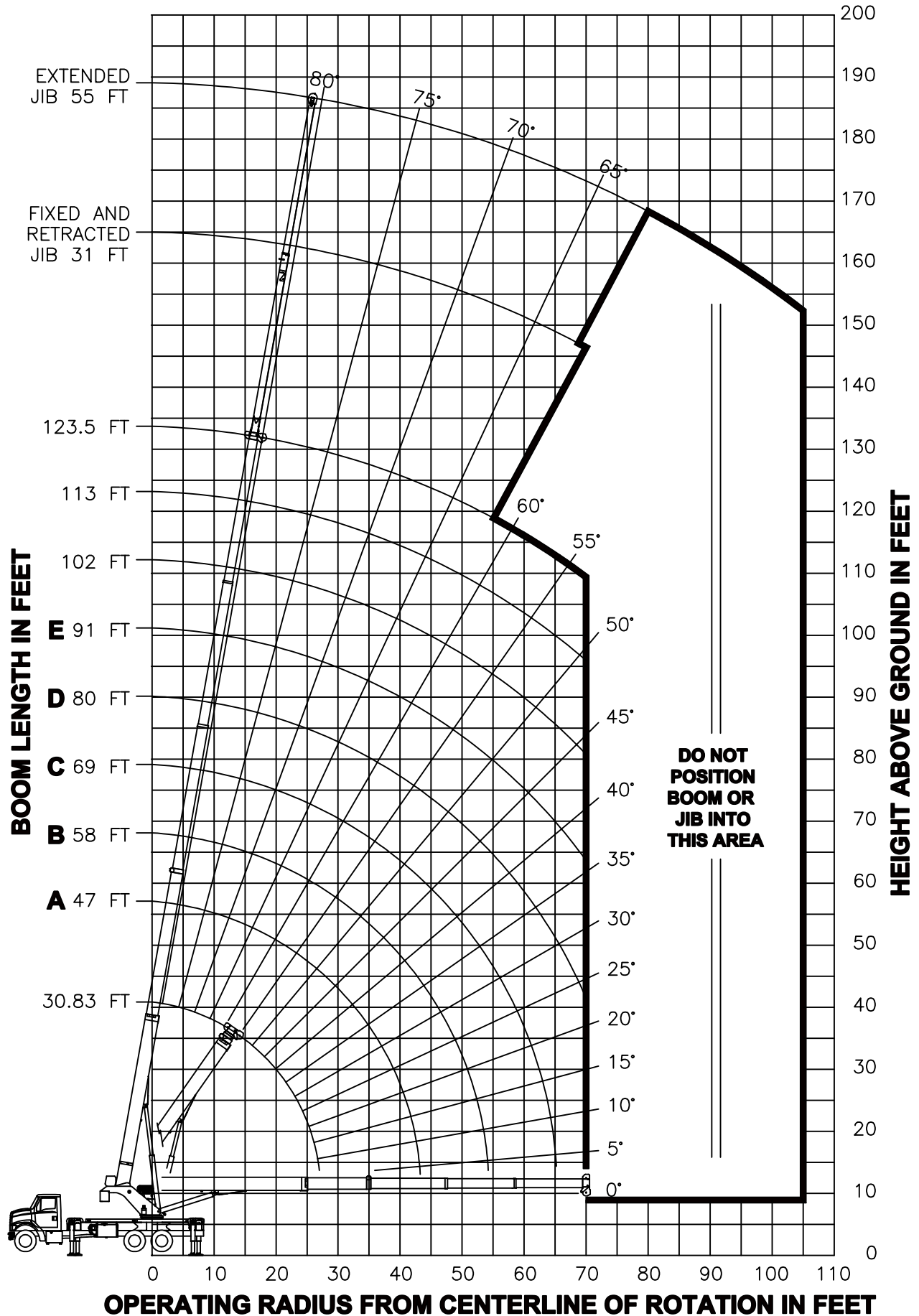

NOTE: LIFTING PERSONNEL WITH CRANE IN THIS OUTRIGGER CONFIGURATION IS STRICTLY PROHIBITED. USE ONLY FULLY EXTENDED OUTRIGGER CONFIGURATION WHEN LIFTING PERSONNEL.

**USE THIS CHART ONLY
WHEN ALL
OUTRIGGERS ARE IN
THE INTERMEDIATE
POSITION**

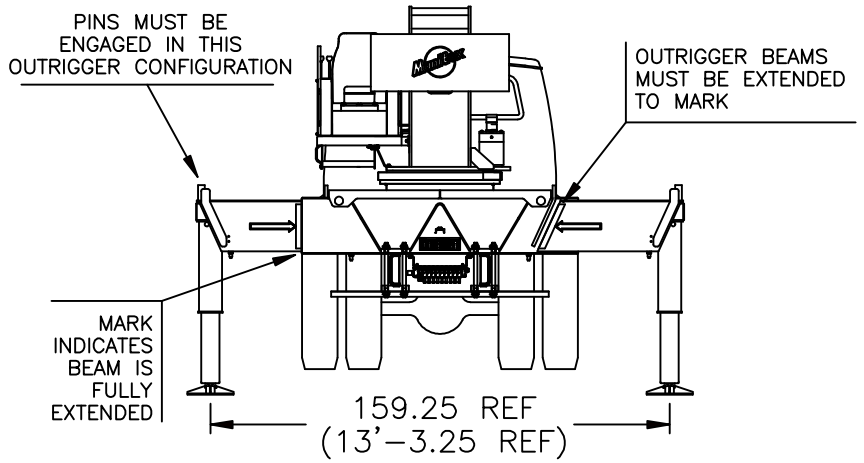

- INTERMEDIATE OUTRIGGER CONFIGURATION -

MAIN BOOM LMI CODE 4																				
LOAD RADIUS (FT)	30.833 FT		47 FT (A)		58 FT (B)		69 FT (C)		80 FT (D)		91 FT (E)		102 FT (F)		113 FT (G)		123.5 FT (H)		LOAD RADIUS (FT)	
	∠	LOAD CAPACITY (LBS)	∠	LOAD CAPACITY (LBS)	∠	LOAD CAPACITY (LBS)	∠	LOAD CAPACITY (LBS)	∠	LOAD CAPACITY (LBS)	∠	LOAD CAPACITY (LBS)	∠	LOAD CAPACITY (LBS)	∠	LOAD CAPACITY (LBS)	∠	LOAD CAPACITY (LBS)		
5	75	80000																	5	
8	69	60500																	8	
10	64	52550	74	25000															10	
12	60	46600	72	25000	76	25000	79	25000											12	
15	53	36000	68	25000	73	25000	76	25000	79	21500									15	
20	40	20410	61	21220	67	21480	72	21650	75	19700	78	17100	79	14500					20	
25	22	13230	53	14050	62	14290	67	14440	71	14550	74	14630	77	13500	78	10910	80	8450	25	
30			45	9930	56	10170	63	10320	67	10420	71	10490	74	10540	76	10430	78	8150	30	
35			36	7250	49	7490	58	7640	63	7740	68	7810	71	7860	73	7900	75	7800	35	
40			22	5350	42	5610	52	5760	59	5860	64	5930	68	5980	71	6010	72	6040	40	
45					34	4220	47	4370	55	4470	60	4530	65	4580	68	4620	70	4650	45	
50					23	3120	40	3290	50	3390	56	3460	61	3510	65	3550	67	3570	50	
55							34	2430	45	2540	52	2610	58	2660	62	2690	65	2720	55	
60							24	1730	39	1840	48	1920	54	1970	59	2000	62	2030	60	
65							6	1110	33	1260	43	1340	51	1390	56	1430	59	1450	65	
70									25	770	38	850	47	900	53	940	57	970	70	
75																			75	
		450 LBS		300 LBS		240 LBS		200 LBS		180 LBS		160 LBS		140 LBS		130 LBS		120 LBS		STOWED FIXED JIB
		840 LBS		560 LBS		450 LBS		380 LBS		330 LBS		290 LBS		260 LBS		230 LBS		210 LBS		STOWED TELE JIB

**DEDUCTIONS FROM MAIN BOOM
CAPACITIES FOR STOWED JIBS**

JIB LOAD CAPACITIES

LOAD RADIUS (FT) REF	31 FT FIXED JIB LMI CODE 34		30.5 FT TELE JIB LMI CODE 19		55 FT TELE JIB LMI CODE 22		LOAD RADIUS (FT) REF
	LOADED BOOM ANGLE (DEG)	LOAD CAPACITY (LBS)	LOADED BOOM ANGLE (DEG)	LOAD CAPACITY (LBS)	LOADED BOOM ANGLE (DEG)	LOAD CAPACITY (LBS)	
30	80	4000	79.5	3300			30
35	78	3850	77.5	3300	79.5	2450	35
40	76	3700	76	3300	78	2450	40
45	74	3550	74	3300	76.5	2450	45
50	72	3400	72	3300	75	2450	50
55	70	3110	70.5	2490	73	2450	55
60	68	2410	68.5	1790	71.5	2450	60
65	66	1830	66.5	1210	70	1930	65
70	64	1340	64.5	720	68	1430	70
75	62	920			66	1010	75
80	60	560			64.5	640	80
85							85

RANGE DIAGRAM - FULLY RETRACTED OUTRIGGER CONFIGURATION -

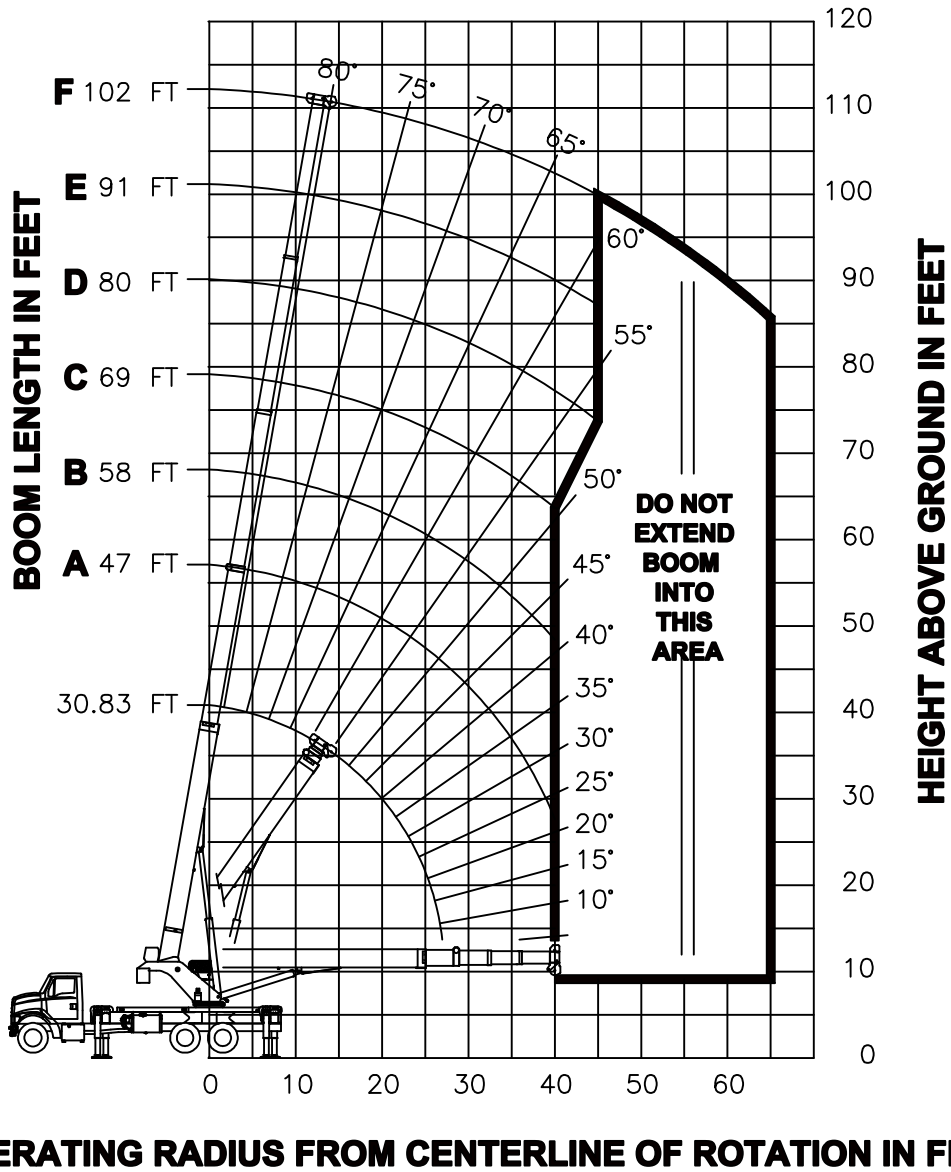

NOTE : LIFTING PERSONNEL WITH CRANE IN THIS OUTRIGGER CONFIGURATION IS STRICTLY PROHIBITED. USE ONLY FULLY EXTENDED OUTRIGGER CONFIGURATION WHEN LIFTING PERSONNEL.

**USE THIS CHART
ONLY WHEN ALL
OUTRIGGERS ARE
FULLY RETRACTED**

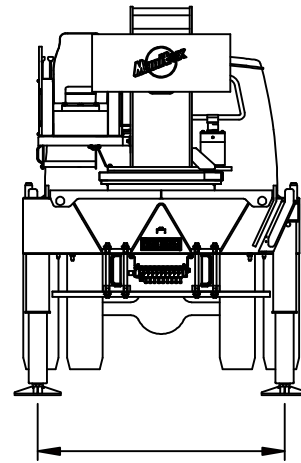

85.75 REF
(7'-1.75 REF)

- FULLY RETRACTED OUTRIGGER CONFIGURATION -

MAIN BOOM LMI CODE 5															
LOAD RADIUS (FT)	30.833 FT		47 FT (A)		58 FT (B)		69 FT (C)		80 FT (D)		91 FT (E)		102 FT (F)		LOAD RADIUS (FT)
	∠	LOAD CAPACITY (LBS)	∠	LOAD CAPACITY (LBS)	∠	LOAD CAPACITY (LBS)	∠	LOAD CAPACITY (LBS)	∠	LOAD CAPACITY (LBS)	∠	LOAD CAPACITY (LBS)	∠	LOAD CAPACITY (LBS)	
5	75	80000													5
8	69	45710													8
10	64	29790	74	25000											10
12	60	21410	72	22160	76	22420	79	22590							12
15	53	14330	68	15020	73	15250	76	15400	79	15500					15
20	40	8240	61	8900	67	9110	72	9250	75	9340	78	9410	79	9460	20
25	22	4930	53	5630	62	5830	67	5960	71	6050	74	6110	77	6160	25
30			45	3580	56	3790	63	3920	67	4000	71	4070	74	4110	30
35			36	2170	49	2390	58	2520	63	2610	68	2670	71	2710	35
40			22	1130	42	1370	52	1500	59	1590	64	1650	68	1690	40
45									55	820	60	880	65	920	45
50															50
55															55
60															60
65															65
70															70
75															75
	450 LBS	300 LBS	240 LBS	200 LBS	180 LBS	160 LBS	140 LBS	STOWED FIXED JIB							
	840 LBS	560 LBS	450 LBS	380 LBS	330 LBS	290 LBS	260 LBS	STOWED TELE JIB							

DEDUCTIONS FROM MAIN BOOM CAPACITIES FOR STOWED JIBS

NOTES :

- LIFTING PERSONNEL WITH CRANE IN THIS OUTRIGGER CONFIGURATION IS STRICTLY PROHIBITED. USE ONLY THE FULLY EXTENDED OUTRIGGER CONFIGURATION WHEN LIFTING PERSONNEL.**
- NO JIBS ARE TO BE ERECTED OR USED IN THIS OUTRIGGER CONFIGURATION.**

ALLOWABLE LINE PULL								WARNING
1 PART LINE	2 PART LINE	3 PART LINE	4 PART LINE	5 PART LINE	6 PART LINE	7 PART LINE	8 PART LINE	
								<p>ANTI-TWO-BLOCK SYSTEM MUST BE IN GOOD OPERATING CONDITION BEFORE OPERATING CRANE.</p> <p>REFER TO THE OWNER'S MANUAL.</p> <p>KEEP AT LEAST 3 WRAPS OF LOAD LINE ON THE DRUM AT ALL TIMES.</p>
9500 LBS	19000 LBS	28500 LBS	38000 LBS	47500 LBS	57000 LBS	66500 LBS	76000 LBS	5/8" ROT RESISTANT (5.0:1 SF) - 47500 LBS MIN BREAKING STRENGTH
10000 LBS	20000 LBS	30000 LBS	40000 LBS	50000 LBS	60000 LBS	70000 LBS	80000 LBS	5/8" 6 X 25 IWRC (3.5:1 SF) - 35000 LBS MIN BREAKING STRENGTH

AREA OF OPERATION

WARNING:

THE MACHINE MUST BE LEVEL AND THE FRONT BUMPER STABILIZER MUST BE SET WHEN OPERATING IN THIS AREA.

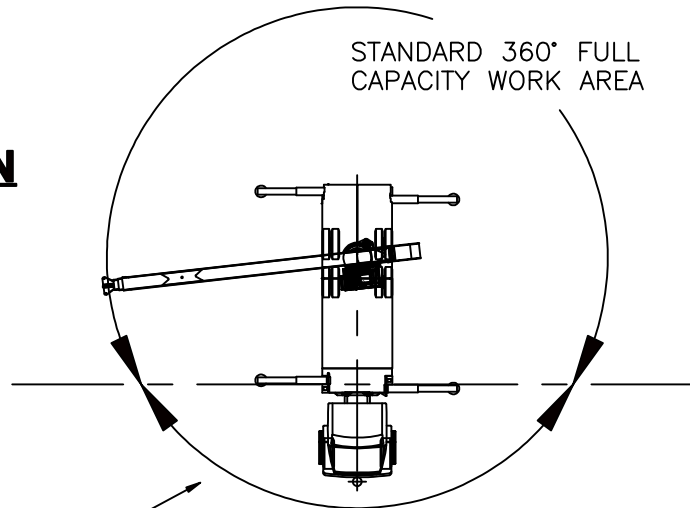

DEDUCTIONS FROM RATED LOADS FOR LOAD HANDLING DEVICES SUPPLIED BY MANITEX

AUXILIARY BLOCK ----- 50 LBS
 OVERHAUL BALL ----- SEE OVERHAUL BALL MFRG. NAMEPLATE
 LOAD BLOCK ----- SEE LOADBLOCK MFRG. NAMEPLATE
 HOSE REEL ----- 260 LBS
 SWING AROUND JIBS (STOWED) ----- SEE LOAD CHART

LMI OPERATING CODES

SETTING	CRANE CONFIGURATION	OUTRIGGER CONFIGURATION
#1	— MAIN BOOM	FULLY EXTENDED
#32	— FIXED JIB	FULLY EXTENDED
#7	— TELESCOPIC JIB—RETRACTED	FULLY EXTENDED
#13	— TELESCOPIC JIB—EXTENDED	FULLY EXTENDED
#25	— PERSONNEL LIFTING PLATFORM ON MAIN BOOM	FULLY EXTENDED
#33	— PERSONNEL LIFTING PLATFORM ON FIXED JIB	FULLY EXTENDED
#26	— PERSONNEL LIFTING PLATFORM ON TELESCOPIC JIB—RETRACTED	FULLY EXTENDED
#29	— PERSONNEL LIFTING PLATFORM ON TELESCOPIC JIB—EXTENDED	FULLY EXTENDED
#4	— MAIN BOOM	INTERMEDIATE
#34	— FIXED JIB	INTERMEDIATE
#19	— TELESCOPIC JIB—RETRACTED	INTERMEDIATE
#22	— TELESCOPIC JIB—EXTENDED	INTERMEDIATE
#5	— MAIN BOOM	FULLY RETRACTED

WARNING

1. THE OPERATOR MUST READ AND UNDERSTAND THE OWNER'S MANUAL BEFORE OPERATING THIS CRANE.

2. POSITIONING OR OPERATION OF CRANE BEYOND AREAS SHOWN ON THIS CHART IS NOT INTENDED OR APPROVED EXCEPT WHERE SPECIFIED IN OWNER'S MANUAL.

3. LOADED BOOM ANGLES AT SPECIFIED BOOM LENGTHS GIVE ONLY AN APPROXIMATION OF THE OPERATING RADIUS. THE BOOM ANGLE BEFORE LOADING SHOULD BE GREATER TO ACCOUNT FOR DEFLECTIONS. DO NOT EXCEED THE OPERATING RADIUS FOR RATED LOADS.

4. THE OPERATING RADIUS SHOWN IN THE JIB RATING CHART IS FOR FULLY EXTENDED BOOM ONLY. WHEN BOOM IS NOT FULLY EXTENDED, USE ONLY LOADED BOOM ANGLE TO DETERMINE LOAD RATING OF JIB.

5. FOR BOOM ANGLES NOT SHOWN ON JIB LOAD RATING CHART, USE RATING OF NEXT LOWER BOOM ANGLE.

6. FOR BOOM LENGTHS NOT SHOWN, USE RATING OF NEXT SHORTER OR LONGER BOOM LENGTH, WHICHEVER IS LESS. FOR RADII NOT SHOWN, USE RATING OF NEXT LONGER RADIUS.

7. CRANE LOAD RATINGS ON OUTRIGGERS ARE BASED ON FREELY SUSPENDED LOADS WITH THE MACHINE LEVELED AND STANDING ON A FIRM UNIFORM SUPPORTING SURFACE. NO ATTEMPT SHALL BE MADE TO MOVE A LOAD HORIZONTALLY ON THE GROUND IN ANY DIRECTION.

WARNING (CONTINUED)

8. PRACTICAL WORKING LOADS DEPEND ON SUPPORTING SURFACE, WIND, AND OTHER FACTORS AFFECTING STABILITY SUCH AS HAZARDOUS SURROUNDINGS, EXPERIENCE OF PERSONNEL, AND PROPER HANDLING, ALL OF WHICH MUST BE TAKEN INTO ACCOUNT BY THE OPERATOR.
9. THE MAXIMUM LOAD WHICH MAY BE TELESCOPED IS LIMITED BY HYDRAULIC PRESSURE, BOOM ANGLE, AND BOOM LUBRICATION. IT IS SAFE TO ATTEMPT TO TELESCOPE ANY LOAD WITHIN THE LIMITS OF THE LOAD RATING CHART.
10. LIFTING OFF THE MAIN BOOM POINT WHILE THE SWING AROUND JIB IS ERECTED IS NOT INTENDED OR APPROVED.

INFORMATION

1. DEDUCTIONS MUST BE MADE FROM RATED LOADS FOR STOWED JIB, OPTIONAL ATTACHMENTS, HOOKS, AND LOAD BLOCKS (SEE DEDUCTION CHART). WEIGHTS OF SLINGS AND ALL OTHER LOAD HANDLING DEVICES SHALL BE CONSIDERED A PART OF THE LOAD.
2. LOAD RATINGS ABOVE THE HEAVY LINE ARE STRUCTURALLY LIMITED CAPACITIES. LOAD RATINGS BELOW THE HEAVY LINE ARE STABILITY LIMITED CAPACITIES AND DO NOT EXCEED 85% OF TIPPING.

DEFINITIONS

1. OPERATING RADIUS IS THE HORIZONTAL DISTANCE FROM THE AXIS OF ROTATION TO THE CENTER OF THE VERTICAL HOIST LINE OR TACKLE WITH LOAD APPLIED.
2. LOADED BOOM ANGLE AS SHOWN IN THE COLUMN HEADED BY \angle , IS THE INCLUDED ANGLE BETWEEN THE HORIZONTAL AND LONGITUDINAL AXES OF THE BOOM BASE AFTER LIFTING RATED LOAD AT RATED RADIUS.